

SWITCHING CIRCUIT

SPECIFICATION MODEL : "PS-5" SERIES

RATING: 16A 125VAC, (UL, CSA)
 16A 250VAC, (UL, CSA)
 16A(4) 250VAC ~ T125/55
 (VDE, SEMKO, DEMKO, NEMKO, FIMKO, SEV)

CONTACT RESISTANCE: 20mΩ (MAX),
 INSULATION RESISTANCE: 500VDC - 100MΩ (MIN).
 WITHSTAND VOLTAGE: 1,000VAC 1 MINUTE.
 ILLUMINATED: 200~250VAC
 OPERATION: 500±200 GRAM.

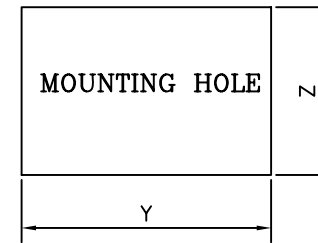
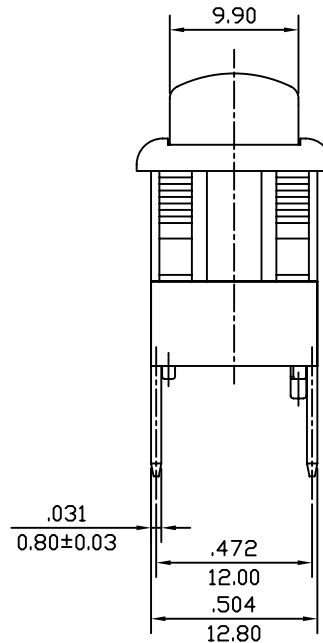
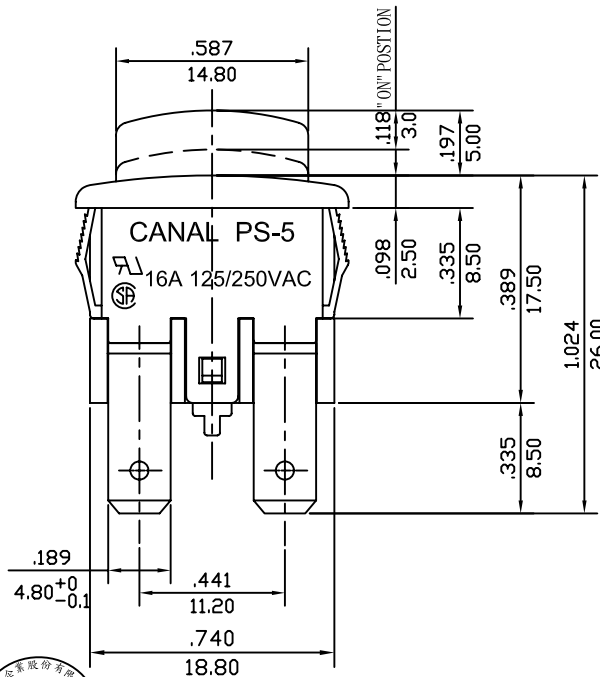

X=Panel thickness	Dim.Y	Dim.Z
0.75~1.25mm	19.2 ⁺⁰ / _{0.1} mm	12.9 ^{+0.15} / ₀ mm
1.25~2mm	19.4 ⁺⁰ / _{0.1} mm	12.9 ^{+0.15} / ₀ mm
2~3mm	19.8 ⁺⁰ / _{0.1} mm	12.9 ^{+0.15} / ₀ mm



NOTE: 1. TOLERANCES UNLESS OTHERWISE SPECIFIED: ±^{.012}/_{0.3} (in/mm)
 2. IT IS IN COMPLIANCE WITH CANAL ROHS SPECIFICATION: WI-QA-24

REVISION	DESCRIPTION	REVISED BY	TOLERANCES .x .xx		ANGLE ½°	UNIT	mm	PART NAME	DWG NO
△			DRAWN BY	劉義正	DESIGNED BY	劉義正	SCALE	5/3	PS-5 SPEC DRAWING
△			CHECKED BY	<i>[Signature]</i>	APPROVED BY	<i>[Signature]</i>	DATE	2007.03.08	
△	2007.03.08 首次出圖.	劉義正					PART NO	PS5-210-PG**-S	S1587A