

L-56BHD

BRIGHT RED

Features

- T-1 3/4 PACKAGE .
- WITH BUILT-IN BLINKING IC.
- OPERATION VOLTAGE FROM 3.5V TO 14V.
- BLINKING FREQUENCY FROM 3.0Hz TO 1.5Hz.

Description

The Bright Red source color devices are made with Gallium Phosphide Red Light Emitting Diode.

Package Dimensions

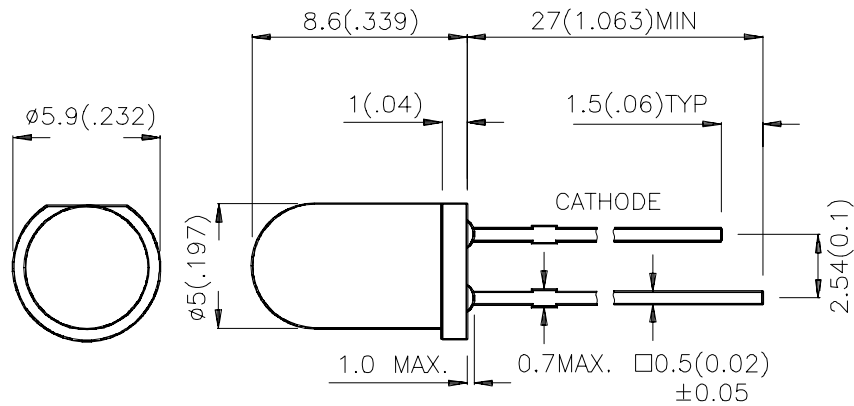

Notes:

1. All dimensions are in millimeters (inches).
2. Tolerance is $\pm 0.25(0.01)$ unless otherwise noted.
3. Lead spacing is measured where the lead emerge package.
4. Specifications are subject to change without notice.

Selection Guide

Part No.	Dice	Lens Type	Iv (mcd) V=9V		Viewing Angle
			Min.	Typ.	2θ1/2
L-56BHD	BRIGHT RED(GaP)	RED DIFFUSED	1.8	5	60°

Note:

1. θ1/2 is the angle from optical centerline where the luminous intensity is 1/2 the optical centerline value..

Electrical / Optical Characteristics at T_A=25°C

Symbol	Parameter	Device	Min	Typ	Units	Test Conditions
λ _{peak}	Peak Wavelength	Bright Red		700	nm	
λ _D	Dominate Wavelength	Bright Red		660	nm	
Δλ _{1/2}	Spectral Line Half-width	Bright Red		45	nm	
I _F	Forward Current	Bright Red	8	22	mA	Min:V _F =3.5V Typ:V _F =5V
I _{SON}	Supply Current	Bright Red		8	mA	V _F =3.5V
I _{SON}	Supply Current	Bright Red		44	mA	V _F =14V
f	Blink Frequency	Bright Red		3	Hz	V _F =3.5V
f	Blink Frequency	Bright Red		1.5	Hz	V _F =14V

Absolute Maximum Ratings at T_A=25°C

Parameter	Bright Red	Units
Power dissipation	310	mW
Forward Voltage	14	V
Reverse Voltage	0.5	V
Operating Temperature	-40°C To +70°C	
Storage Temperature	-40°C To +85°C	
Lead Solder Temperature [1]	260°C For 5 Seconds	

Note:

1. 2mm below package base.

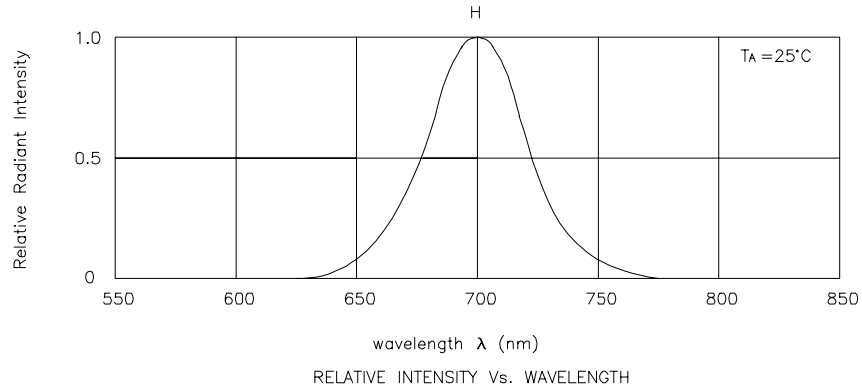

Bright Red L-56BHD

